

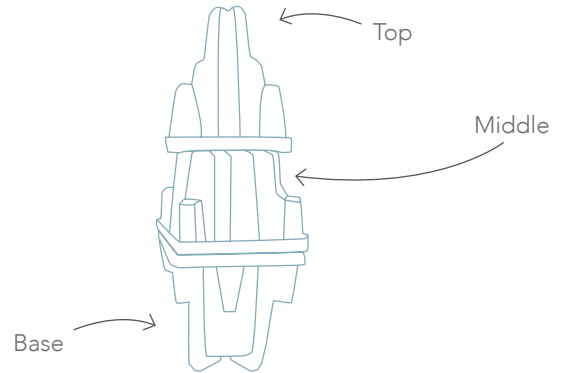

EZEE GROUP USA has created an easy to use system, making our product quick to pack, saving you time and money. Below are the key steps to ensure your product is packed correctly. Confirmation of the correct type of box will be required to ensure that the molds are secured effectively.

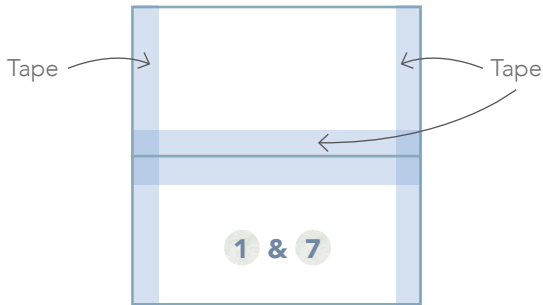

BOX & TAPING

Make sure you have the correct box size for the molds. This is essential to ensure the molds are held securely in place during transit. If you are unsure of which box size you require please contact us and we can help.

The box should be taped up using the **H** pattern method. Taping up both edges and the center fold of the box. This stops the box edges from snagging during transit.

PRODUCT & MOLDS

Check you are using the correct molds for the product. This is essential to ensure the molds hold the product securely in place during transit.

Our single, 3-bottle & 6-bottle molds always require three molds, one for the base, one for the middle and one for the top.

Our 12-bottle molds always require two molds, one for the base and one for the top.

PACKING YOUR PRODUCT

- 1 Make the box up using the **H** pattern method described above.
- 2 Place the base molds in the base of the box.
- 3 Insert your product into the base mold.
- 4 Place the middle mold directly over the top of the product. (N/A for 12-bottle).
- 5 Place the top mold on the top of the product.
- 6 Close the flaps of the box, ensuring they press firmly down onto the top mold. This is very important, to ensure no vertical movement within the box.
- 7 Securely tape the box using the **H** pattern method described above.

